



www.icecompanies.com

Operator & Parts Manual

Floor Machine & Foam Generator



**IF17
IFG6**

The Peoples
COMPANY

4110901
REV.02(12-2012)

INTERNATIONAL CLEANING EQUIPMENT



READ OPERATOR MANUAL CAREFULLY

IMPORTANT: To ensure full warranty protection, Please fill out & return your warranty card.

Please fill out at time of installation for future reference.

Model No. _____

Serial No. _____

Machine Options _____

Sales Rep. _____

Sales Rep. phone no. _____

Customer ID Number _____

Installation Date _____

HOW TO ORDER PARTS

Only use ICE Company supplied or equivalent parts. Parts and supplies may be ordered online, by phone, by fax or by mail.

1. Identify the machine model.
2. Identify the machine serial number from the data label.
3. Ensure the proper serial number is used from the parts list.
4. Identify the part number and quantity.

Do not order by page or reference numbers.

5. Provide your name, company name, customer ID number, billing and shipping address, phone number and purchase order number.



PROTECT THE ENVIRONMENT

Please dispose of packaging materials, old machine components such as batteries, hazardous fluids, including antifreeze and oil, in an environmentally safe way according to local waste disposal regulations.

Always remember to recycle.



International Cleaning Equipment Co., Ltd.
XiangShi Road LiaoBu DongGuan GuangDong China
Tel: 0769-8186 9000
Fax: 0769-8186 3000

Specifications and parts are subject to change without notice.

TABLE OF CONTENTS

SAFETY PRECAUTIONS	4
MACHINE COMPONENTS	5
MACHINE OPERATING INSTRUCTIONS	6
MACHINE MAINTENANCE & STORAGE	6
DRYER FOAM GENERATOR COMPONENTS	7
DRYER FOAM GENERATOR OPERATING INSTRUCTIONS. . .	7
DRYER FOAM GENERATOR MAINTENANCE.	7
PARTS LIST	8
SAFETY PRECAUTIONS(CHINESE)	17
MACHINE MAINTENANCE & STORAGE (CHINESE)	17
MACHINE OPERATING INSTRUCTIONS(CHINESE)	18
MACHINE COMPONENTS(CHINESE)	18
DRYER FOAM GENERATOR COMPONENTS(CHINESE)	19
DRYER FOAM GENERATOR OPERATING INSTRUCTIONS AND MAINTENANCE(CHINESE)	19
SPECIFICATIONS	20
WEAR & TEAR PARTS LIST	21
WIRING DIAGRAM	22

SAFETY PRECAUTIONS



Carefully read and understand this manual before operating this machine.
This machine must be grounded!

This floor/finishing machine shall be grounded while in use to protect the operator from electric shock. Grounding provides a path of least resistance for electric current. This machine is equipped with a cord having an equipment-grounding conductor and grounding plug. The plug must be plugged into an appropriate outlet that is properly installed and grounded in accordance with all local codes and ordinances. Do not remove the ground pin under any circumstances.

This machine is for use on a nominal 220-volt circuit and has a grounding plug that resembles the plug illustrated in Figure. Make sure that the machine is connected to an outlet having the same configuration as the plug. No adapter should be used with this machine.

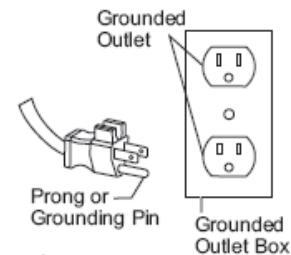

This machine is intended for commercial use. It is constructed for use in an indoor environment and is not intended for any other use. Use only recommended accessories.

1. Do not operate machine:

- Unless trained and authorized.
- In flammable or explosive areas.
- With a damaged cord or plug
- If not in proper operating condition.
- Unless you have read and understand the operator's manual.
- With the use of extension cords.
- In outdoor areas and standing water.

2. Before operating machine:

- Make sure all safety devices are in place and operating properly.

3. When using machine:

- Do not run machine over cord.
- Do not pull cord around sharp edges or corners.
- Do not handle plug with wet hands.
- Report machine damage or faulty operation immediately.
- Do not pull machine by cord or plug.
- Do not unplug by pulling on the cord.
- Do not stretch cord.
- Keep cord away from heated surfaces.

4. Before leaving or servicing machine:

- Turn off machine.
- Unplug cord from outlet.

5. When servicing machine:

- Unplug cord from outlet.
- Use manufacturer supplied or approved replacement parts.



To avoid electrical shock, please replace the power cord immediately if any damage is being detected. The replacement must be performed only by an authorized person or by our customer service center.

MACHINE COMPONENTS

Machine Description

- New structure design
- 17" Deck aluminium
- 16" Pad driver and 17" brush
- Engineering plastics gear
- Buffer device, quiet, easy operation
- Universal clutch plate
- Safety lock-out switch
- 50' Cord

Machine Structure

- | | |
|----------------|---------------------------|
| 1. Deck | 2. Wheel |
| 3. Handle | 4. Safety lock-out switch |
| 5. Trigger | 6. Leveling rod |
| 7. Housing | 8. Solution tank |
| 9. Top cover | 10. Motor |
| 11. Iron block | 12. Clutch plate |

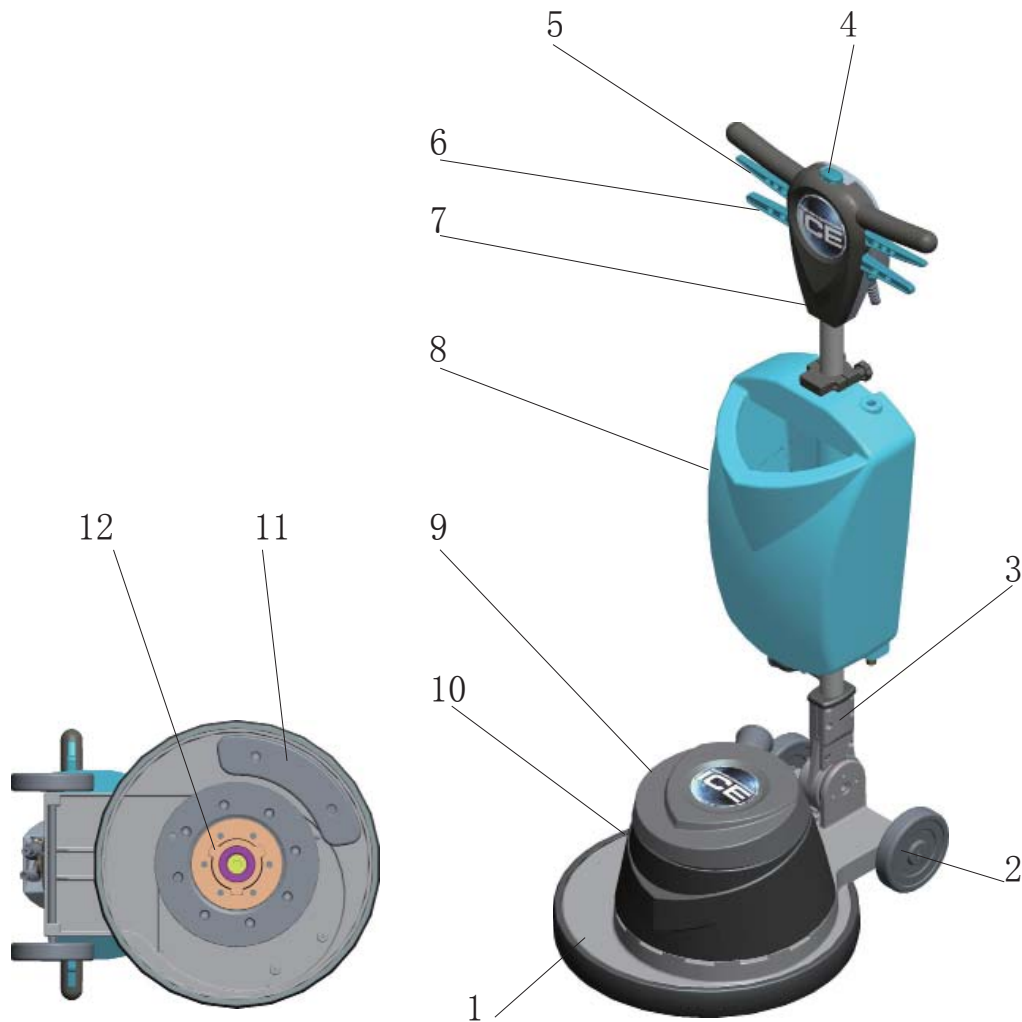

FLOOR MACHINE OPERATING INSTRUCTIONS

General Use:

- 1) Remove any obstructions or other obstacles in the area which is to be cleaned.
- 2) Place handle in upright position and tilt machine back until handle rests on the floor.



Be sure the machine is not plugged into an outlet.

- 3) Remove the pad center gripping device by unscrewing the thumbscrews.
- 4) Place appropriate burnishing pad on pad driver and re-attach the center gripping device.
- 5) Place machine back into its upright position.
- 6) Plug power cord into grounded outlet.



Do not use an extension cord in conjunction with the standard power cord.

- 7) Adjust the handle (switch housing) height to a comfortable operating position.
- 8) To start the machine, push on the Blue safety button of the top of upper switch housing and squeeze either of the switch levers.
- 9) When the machine is in operation, both hands should be placed on the handle (switch housing).
- 10) To stop the machine at any time, simply release the switch lever, and the machine will stop automatically.

MAINTENANCE

To keep the machine performing well for many years, please follow the following maintenance procedures.



Always confirm that the machine is unplugged prior to performing any maintenance or repairs.

1. Unplug machine as soon as you are done using it.
2. Tilt machine back and remove pad driver or brush.



Never store a low speed machine with the pad driver or brush mounted to the machine.

3. Clean the outside of the machine with a mild cleaner.
4. Check power cord for any damage. If damage is detected, replace power cord immediately.
5. Lubricate wheels with a water resistant lubricant once a month.
6. Check machine for loose or missing nuts and bolts, and replace as necessary.
7. If the machine is used in a dusty environment, you may remove the motor cover and blow the motor clean with compressed air. This will ensure proper ventilation, and allow the motor to run cooler.

STORAGE

- 1) Unplug machine from power source and wrap cord on handle.
- 2) Tilt machine back and remove pad driver or brush.
- 3) Store in upright position in a dry area.

FOAM GENERATOR COMPONENTS

- | | | |
|-------------------------|-------------------|---------------------|
| 1. Hint | 2. Body | 3. Foam Filter knob |
| 4. Foam adjustment knob | 5. Exhaust button | 6. Front cover |
| 7. Solution inlet | 8. Clamp | 9. Filter |
| 10. Power cord | 11. Foam outlet | |

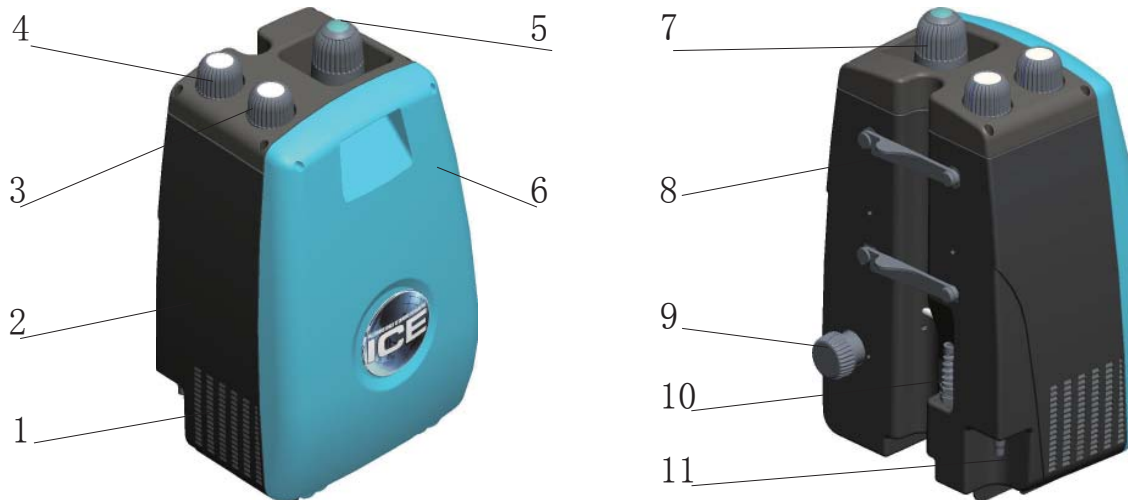

FOAM GENERATOR OPERATING INSTRUCTIONS



Please follow the Instructions to achieve the top performance.

- 1.INSTALLATION:** Set IF17 polisher at the up-right position. Install the foam generator on the handle tube of the polisher and lock the Holding Handle in position. Connect the Foam Outlet Hose to the fitting on the polisher. Connect the power cord to the socket on the polisher rear the handle housing.
- 2.SOLUTION:** Mix the ICE carpet cleaner with water(ratio:1:15). Pour into the Solution Inlet gently. NOTE: tank capacity is 6 liters.
- 3.CARPET CLEANING:** Set the polisher in working position(lowering the handle). Turn the Foam Adjusting Knob(min.1/max.3) , wait for 3-5 seconds, adjust the Foam Adjusting Knob for desired Foam volume. Turn the Foam Adjusting Knob to 0 position to switch off the machine.



DO NOT turn on the polisher until seeing the foam coming out of the shampoo brush.

FOAM GENERATOR MAINTENANCE

- 1.Foam Filter,Inlet Filter and Hint Filter need to be cleaned periodically.
- 2.Please check up the filters if foam volume is less than normal.
- 3.Please empty the tank after each usage, Remaining chemical may cause chemical residue and operating failure.

IF17 HANDLE ASSEMBLY

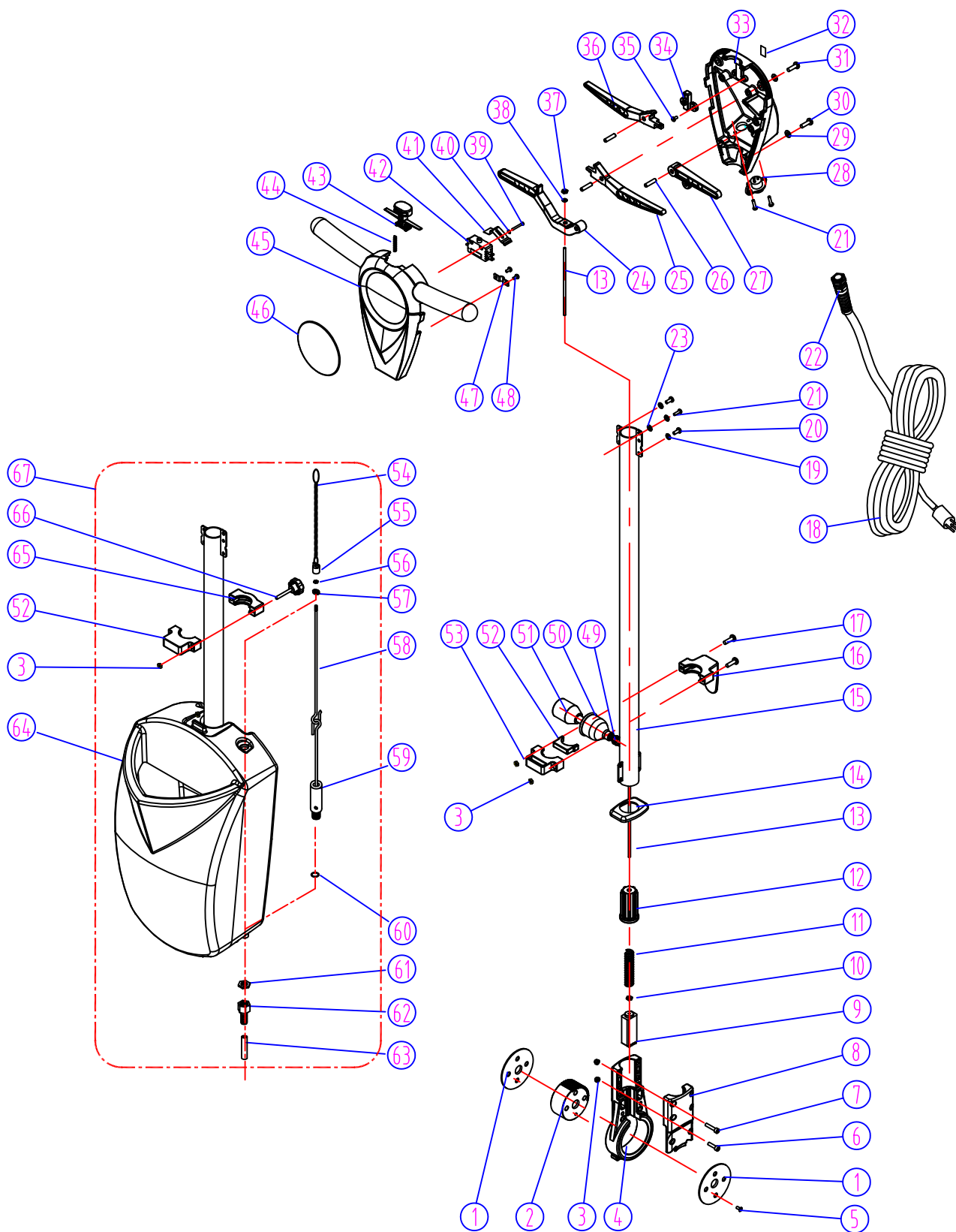

IF17 HANDLE ASSEMBLY

DIA NO	PART NUMBER	DESCRIPTION	NO REQ'D
1	4010212	COVER 密封端盖	2
2	4010210	GEAR 调位齿轮	1
3	1113507	NUT,LOCK,M5 六角锁紧螺母 M5	10
4	4010201	MOUNTING BASE,GEAR 齿轮座体	1
5	1212410	SCREW M4 X 10 十字沉头螺钉 M4 X 10	2
6	1511525	SCREW M5 X 25,HEX SOCKET 内六角圆柱头螺钉 M5 X 25	2
7	1511530	SCREW M5 X 30,HEX SOCKET 内六角圆柱头螺钉 M5 X 30	4
8	4010202	COVER,SEAT GEAR 盖板	1
9	4010211	INSERT 调位齿杆	1
10	1111403	NUT, M4 六角头螺母 M4	1
11	4010208	SPRING LEVELING 拉杆弹簧	1
12	4010207	SEAT,SPRING 拉杆套	1
13	4010214	ROD LEVELING 长拉杆	1
14	4010216	SEAL,SEAT 防水胶套	1
15	4010204	TUBING 主管	1
16	4010405	HOOK,CABLE 绕线架	1
17	1511540	SCREW M5 X 40,HEX SOCKET 内六角圆柱头螺钉 M5 X 40	2
18	4010318	CORD,POWER SUPPLY 电源线	1
19	1434500	TOOTH WASHER Ø5 齿型垫圈 Ø5	4
20	1211512	SCREW M5X12 十字盘头螺钉 M5X12	4
21	1211414	SCREW M4X14 十字盘头螺钉 M4X14	3
22	4010310	STRAIN RELIEF,CORD 电源线保护套	1
23	1434400	TOOTH WASHER Ø4 齿型垫圈 Ø4	2
24	4010324	LEVELING ROD 调位拉把	1
25	4010321	TRIGGER, SWITCH, LEFT 开关左拉把	1
26	4010314	PIN 销轴	4
27	4010325	LEVEL,SOLUTION 放水拉把	1
28	4110303	OUTLET,FOAM GENERATOR 泡箱插座	1
29	1421616	WASHER,PLAIN Ø6 平垫圈	4
30	1512635	SCREW M6 X 35 内六角平圆柱头螺钉 M6 X 35	2
31	1512625	SCREW M6 X 25 内六角平圆柱头螺钉 M6 X 25	2
32	4110313	SERIAL NUMBER 连续号贴纸	1
33	4110301	REAR,COVER 手柄后盖	1
34	4010317	SEAT,BALL 钢球座	1
35	1211408	SCREW,M4X8 十字盘头螺丝 M4 X 8	2
36	4010322	TRIGGER, SWITCH, RIGHT 开关右拉把	1
37	1123406	NUT,LOCK,M4 六角锁紧螺母 M4	1

IF17 HANDLE ASSEMBLY

DIA NO	PART NUMBER	DESCRIPTION	NO REQ'D
38	1421412	WASHER,Ø4 平垫片	1
39	1211325	SCREW,M3X25 十字盘头螺钉 M3X25	2
40	1434300	TOOTH WASHER Ø3 齿型垫圈	4
41	4010323	SPRING,SWITCH 开关弹簧	1
42	4010308	SWITCH 开关	1
43	4010307	SAFETY BOTTOM 保险键	1
44	4010326	SPRING,SAFTY 保险弹簧	1
45	4010301	FRONT COVER 前盖	1
46	4010316	ICE,LOGO ICE 标牌	1
47	4010311	CLAMP,CORD 压线块	1
48	1221406	SCREW,M4X6 十字盘头螺丝 M4 X 6	2
49	4010213	GROMMET 电源线保护胶圈	1
50	4010120	PLUG PROTECTOR COVER 防水盖	1
51	4010215	CORD,HANDLE 手柄内电线	1
52	4010430	GASKET 橡胶垫	1
53	4010402	CLAMP,HOOK 固定夹	2
54	4010423	CHAIN 链条	1
55	4010419	SEAT,CHAIN 链条座	1
56	4010412	SCREW,M5,BRASS 铜螺母 M5	1
57	4010418	SEAL,TANK 水箱拉杆密封套	1
58	4010427	UPPER PULLING ROD BRASS 上拉钩	1
59	4010428	VALVE ASSEMBLY 阀组件	1
60	4010429	SEAL 密封垫	1
61	4010426	NUT,1/2-20UNF 螺母 1/2-20	1
62	4010425	BARB,HOSE,SOLUTION 放水阀接头	1
63	4010406	BARB HOSE 溶液管	1
64	4010401	TANK 水箱	1
65	4010403	CLAMP,TANK 水箱固定块	1
66	4010404	KNOB M5X40 水箱紧固手把	2
67	4015000	SOLUTION TANK ASSEMBLY 水箱组件	1

IF17 BASE ASSEMBLY

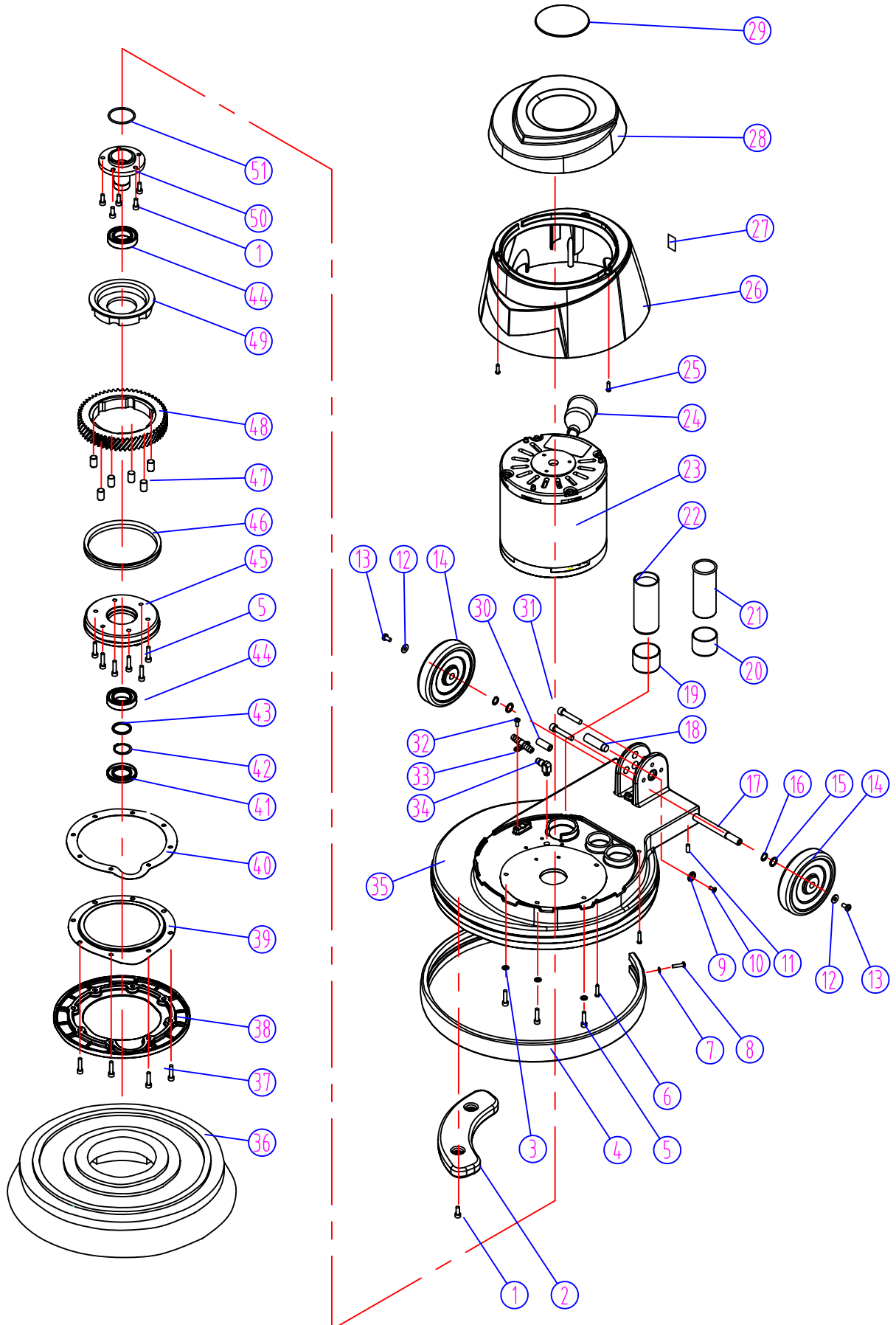

IF17 BASE ASSEMBLY

DIA NO	PART NUMBER	DESCRIPTION		NO REQ'D
1	1521616	HEX SOCKET SCREW,M6 X 16	内六角圆柱头螺钉 M6 X 16	7
2	4110108	IRON BAR	配重块	1
3	1411612	WASHER,PLAIN Ø6	平垫圈	4
4	4110121	BUMPER,FRAME	防撞边	1
5	1521625	HEX SOCKET SCREW,M6 X 25	内六角圆柱头螺钉 M6 X 25	10
6	1313325	SELF-TAPPING SCREW ST4.8 X 25	十字盘头自攻丝, ST4. 8X25	4
7	1421510	WASHER,PLAIN Ø5	不锈钢平垫圈	4
8	1221514	SCREW M5 X 14,PH	十字盘头螺钉 M5 X 14	2
9	4010114	WASHER	轴端档圈	1
10	1222512	SCREW,M5 X 12	十字沉头螺钉, M5X12	1
11	1534608	SCREW,M6 X 8	内六角紧定螺钉, M6X8	2
12	1421618	WASHER,PLAIN Ø6	平垫圈	2
13	4010111	SCREW,M6 X 12.7	防松螺钉 M6 X 12.7	2
14	4210116	WHEEL,5"	轮子	2
15	1421625	WASHER,PLAIN Ø12	平垫圈	2
16	1436012	WASHER,LOCK,12	轴用弹性挡圈 Φ12	2
17	4010615	AXLE	轮轴	1
18	4010110	SHAFT	固定轴	1
19	4010113	SEAL,CAPACITOR	电容垫	1
20	4110116	SEAL,CAPACITOR	电容垫	1
21	4110801	RUNNING CAPACITOR,16uf/450v,105 ° c	电容器 16UF/450V 105 ° C	1
22	4010803	START-UP CAPACITOR(BIG),200UF/250V	起动电容 200UF/250V	1
23	4110800	MOTOR	电机	1
24	4010118	PLUG PROTECTOR SAMLL MALE	电机防水套	1
25	1311219	SELF-TAPPING SCREW ST4.2 X 19	十字盘头自攻螺钉, ST4. 2X19	3
26	4110102	COVER,MOTOR	电机罩	1
27	4010115	READ MANUAL LABEL	贴纸	1
28	4110103	TOP,COVER	电机顶盖	1
29	4010316	LOGO,ICE	"ICE"标牌	1
30	4110120	TUBING	水管	1
31	1521845	SCREW M8 X 45,HEX SOCKET	内六角圆柱头螺钉(防松) M8X45	3
32	1211512	SCREW M5X12	十字盘头螺钉 M5X12	2
33	4110117	BARB HOSE	放水接头	1
34	4110119	ELBOW	直接头	1

IF17 BASE ASSEMBLY

DIA NO	PART NUMBER	DESCRIPTION	NO REQ'D
35	4110101	FRAME 17"壳体	1
36	9021017	15"BRUSH WITH FOAM SLOT 15"带泡槽洗地刷	1
	9020017	15"BRUSH 15"洗地刷	1
	9010016	16"PAD 16"针座	1
37	1521620	HEX SCREW,M6 X 20 内六角螺丝 M6 X 20	8
38	4110106	COVER,GEAR 铝盖板	1
39	4110105	PLATE 挡板	1
40	4110114	GASKET 橡胶密封垫	1
41	1635530	SEAL FB30 X 55 X 7 唇形密封圈	1
42	1436030	RETAINING RING,EXTERNAL, ϕ 30 轴用弹性挡圈	1
43	4110112	SPACER,BEARING 轴承隔套	1
44	1612606	BEARING,6006RS 双面防尘盖球轴承 6006RS	2
45	4110109	CLUTCH PLATE 卡扣座	1
46	4110113	GASKET 密封圈	1
47	4110111	PIN 销轴	6
48	4110104	GEAR,PLASTIC 塑料齿轮	1
49	4110110	SEAT,GEAR 齿轮座	1
50	4110107	SHAFT 铜轴	1
51	1622745	"O"RING, ϕ 2.65 X ϕ 44.7 "O"型密封圈	1

IFG6 ASSEMBLY

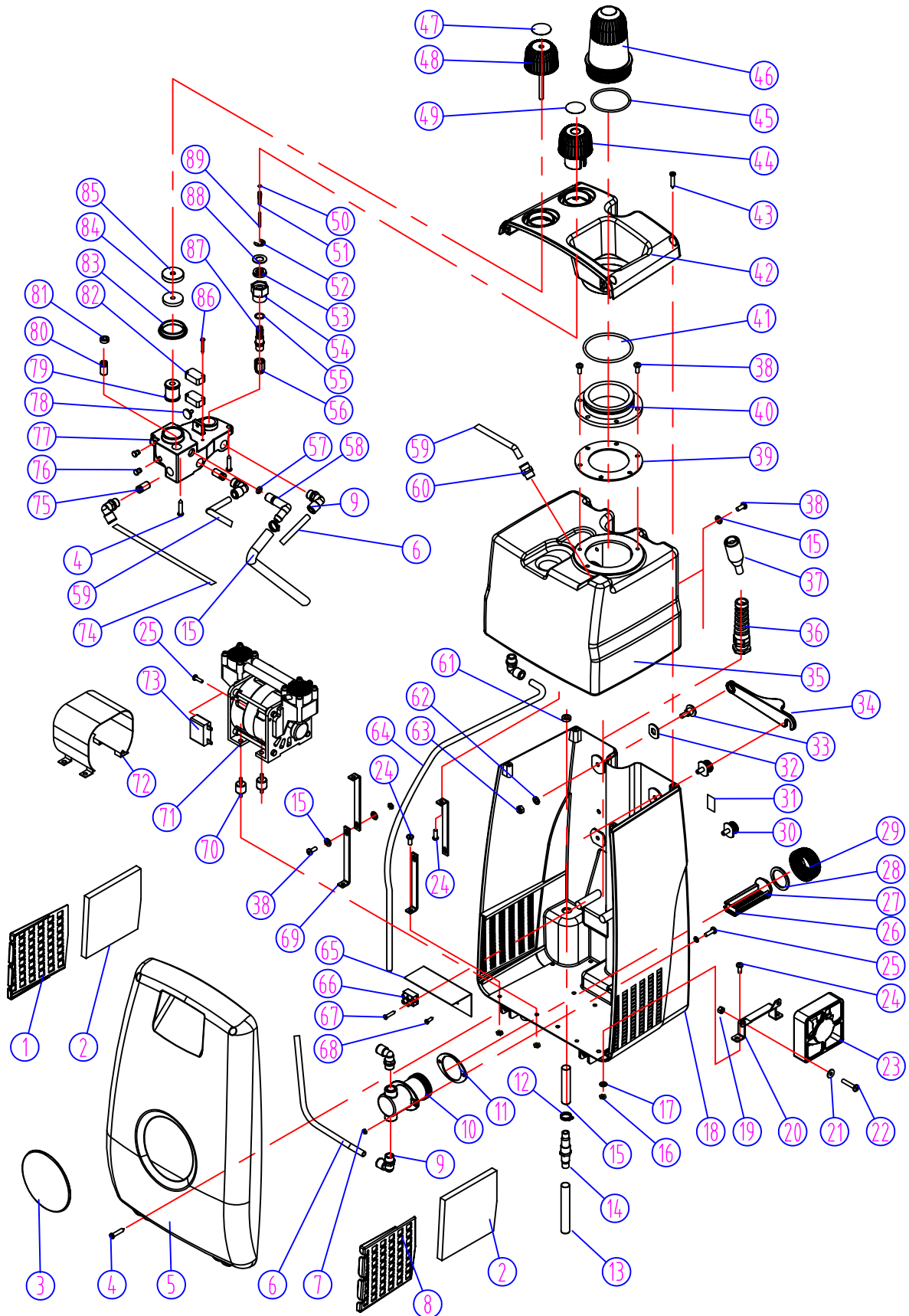

IFG6 FOAM GENERATOR

DIA NO	PART NUMBER	DESCRIPTION	NO REQ'D
1	4160177	BRACKET,FILTER 过滤网支架(左)	1
2	4160154	FILTER,AIR 空气过滤网	2
3	4010316	ICE,LOGO ICE 标牌	1
4	1311319	SELF-TAPPING SCREW ST4.8 X 19 十字盘头自攻丝, ST4. 8X19	6
5	4160102	FRONT COVER 前盖	1
6	4160158	TUBING,Φ6XΦ8 滤网出水管	1
7	1111403	NUT, M4 六角头螺母 M4	2
8	4160155	BRACKET,FILTER 过滤网支架(右)	1
9	4160150	ELBOW,NPT1/4" 快换90度接头	6
10	4160132	SEAT,FILTER 过滤器座	1
11	4160133	GASKET 密封圈	1
12	1962016	CLAMP,HOSE 喉箍	2
13	4010406	TUBING 溶液管	1
14	4160147	BARB 出泡直接头	1
15	4160160	TUBING,Φ10XΦ15 出泡管	1
16	1113507	NUT,LOCK,M5 六角锁紧螺母 M5	10
17	1421510	WASHER,PLAIN Ø5 不锈钢平垫圈	12
18	4160101	BODY 泡箱箱体	1
19	1123406	NUT,LOCK,M4 六角锁紧螺母 M4	2
20	4160153	BRACKET, FAN 风扇支架	1
21	1421412	WASHER,Ø4 平垫片	4
22	1211435	SCREW,M4 X 35 ,PH 十字盘头螺钉 M4 X35	2
23	4160152	FAN 风扇	1
24	1221512	SCREW M5X12 十字盘头螺钉 M5X12	6
25	1211414	SCREW M4X14 十字盘头螺钉 M4X14	3
26	4160136	MESH,UPPER 小滤网	1
27	4160135	MESH,LOWER 滤网	1
28	4160134	SEAL 密封垫	1
29	4160108	COVER,FILTER 过滤器盖	1
30	4160139	SCREW 定位螺杆	2
31	4160120	SERIAL NUMBER 连续号贴纸	1
32	4160138	WASHER 垫片	2
33	4160137	PIN 泡箱固定轴	2
34	4160141	CLAMP,PLATE 泡箱固定手把	2
35	4160109	TANK 水箱	1
36	4160181	STRAIN RELIEF,CORD 线尾套	1
37	4160183	CORD,POWER SUPPLY 电源线	1
38	1221514	SCREW M5X14 十字盘头螺丝 M5 X 14	12
39	4160144	GASKET,INTAKE,TANK 水箱法兰垫	1
40	4160142	FRANGE,TANK 水箱法兰	1
41	1624067	"O"RING,Ø4 x Ø67 0型密封圈Ø4 x Ø67	1
42	4160103	TOP COVER 顶盖	1
43	1321319	SELF-TAPPING SCREW ST4.8 X 19 十字盘头自攻丝, ST4. 8X19	4
44	4160140	KNOB,ADJUSTING 调节手把	1
45	1624060	"O"RING,Φ4XΦ60 0型密封圈Φ4XΦ60	1

IFG6 FOAM GENERATOR

DIA NO	PART NUMBER	DESCRIPTION	NO REQ'D
46	4160148	KIT,TANK KNOB,INTAKE 水箱盖手把套装 (连放气阀)	1
47	4160176	ICON,FOAMING 发泡图标	1
48	4160104	KNOB ASSY,FOAMING 发泡旋钮组合件	1
49	4160175	ICON,ADJUSTING 调节图标	1
50	1621104	"O"RING,Φ1XΦ3.5 0型密封圈 Φ1XΦ3.5	1
51	4160115	SCREW 定位螺杆	1
52	1439008	RETAINING RING EXTERNAL,Ø8 开口挡圈 Ø8	1
53	4160119	"Y"RING,Ø12 Y型密封圈 D12	1
54	4160112	NUT,ADJUSTING VALVE 阀芯螺母	1
55	4160117	WASHER,NYLOY 尼龙垫片	1
56	4160114	BIG NUT 六方轴	1
57	1622009	"O"RING,Φ2XΦ9 0型密封圈 Φ2XΦ9	1
58	4160126	ELBOW,BARB 90度接头	1
59	4160159	TUBING,Φ6XΦ8 水箱进气管	1
60	4160143	BARB 快换直接头	1
61	1112207	NUT,M14X1.5 M14X1.5螺母	1
62	1411612	WASHER,PLAIN Ø6 平垫圈	4
63	1113605	NUT,LOCK,M6 六角锁紧螺母 M6	4
64	4160157	TUBING,Φ6XΦ8 水箱出水管	1
65	4160145	PLATE 档水板	1
66	4160146	CONNECTOR 接线座	1
67	1321219	SELF-TAPPING SCREW ST4.2 X 20 十字盘头自攻螺钉, ST4. 2X20	1
68	1321210	SELF-TAPPING SCREW ST4.2 X 9.5 十字盘头自攻螺钉, ST4. 2X9.5	1
69	4160156	SUPPOTR,UPPER 水箱支撑筋	2
70	4160803	MOUNTING SCREW,PUMP 电机固定螺丝套装	4
71	4160800	PUMP.220V 电机	1
72	4160178	SHIELD,PUMP 挡水板	1
73	4160801	CAPACITOR 2UF 电容 2uf	1
74	4160161	TUBING,Φ6XΦ8 发泡座进气管	1
75	4160167	VALVE 气阀组件(软)	2
76	4160125	COVER 封堵卡	5
77	4160110	VALVE BODY 发泡座	1
78	4160122	PIN 连接轴	1
79	4160130	FOAMING GENERATOR 发泡过滤器	1
80	4160123	VALVE 气阀(硬)	1
81	4160124	NUT,M14 开槽紧固螺母 M14*2	1
82	4160151	MICRO SWITCH 开关	2
83	4160131	GASKET 密封圈	1
84	4160129	SEAL 密封垫	1
85	4160128	BUSH 保护套	1
86	1211325	SCREW,M3X25 十字盘头螺钉 M3X25	2
87	4160113	PIN,ADJUSTING VALVE 药水调节阀芯	1
88	4160116	WASHER 垫片	1
89	4160118	PIN 限位杆	1

安全预防



在使用本机器前请仔细阅读和理解操作手册
本机必须接地！

为减少机器因故障而引起的触电危险，本机电源线插头带有一接地插脚，任何情况下不得去除该插脚。

本机使用额定 220 伏电压和有接地插头供电系统。其结构类似于附图。确保本机连接到具有相同配置的插头插座。无需适配器。

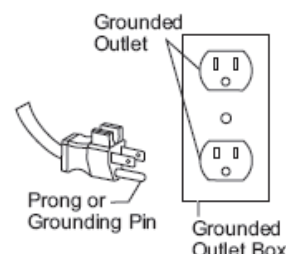

本机仅作商业用途，并限于户内使用。务必使用推荐的附件，操作者应阅读，理解并掌握以下安全预防措施：

1、以下情况不得操作本机：

- 未经培训取得相应资格；
- 在易燃易爆场所；
- 机器存在问题不适合操作；
- 在水中；
- 未仔细阅读和理解操作手册；
- 电源线或插头损坏；
- 在户外时；
- 使用延长线；

2、操作机器前：务必确保所有安全装置动作正常；

3、使用机器时：

- 不得碾压电线；
- 不得将电线置于物件锋利的边、角；
- 切勿用湿手拔取插头；
- 应立刻报告机器任何之异常及损坏情况；
- 不得靠牵拉电线的方式移动机器；
- 不得用拉电线的方式拔取插头；
- 始终使电源线远离发热的物件表面；

4、离开机器或进行维护前：务必关机并拔下电源插头；

5、进行维护时：

- 应拔下电源插头；
- 使用生产商推荐或认可的配件；

储存时：1、拔下电源插头；2、取下针座或刷子；3、直立存放于干燥的场所；

维护与保养

为使本机始终保持良好的性能，请遵循以下程序保养本机



进行任何维护、保养工作前，必须确保机器已断开电源。

- 1、机器一经使用完毕，立即拔下电源插头；
- 2、取下针座或刷子；



存放机器时，切勿忘记取下针座或刷子

- 3、用中性清洁剂清洁机器；
- 4、检查机器电源线有无破损，如有应立即进行更换；



为避免危险，若电源线破损，必须联系当地售后服务部进行更换；

- 5、每月用防水润滑剂润滑轮子、轴；

- 6、检查机器有否遗失螺母、螺栓并进行更换；

- 7、机器在粉尘的场所使用后，应取下电机顶盖，用压缩空气吹净附着在电机上的灰尘以保证良好的通风。

操作说明



使用或维护本机前务必仔细阅读说明书

- 1、使用前应清理工作区域内的杂物、纸屑等；
- 2、将手柄置于垂直位置后，将机器倾斜使手柄靠在地面；



确认机器此时未接通电源；

- 3、松开螺母，取下中心定位器；4、取合适的抛光垫粘在针座上，并用中心定位器压紧；
- 5、将机器置于垂直位置；6、将电源线插头插入带接地的插座中；



切勿使用与电源线不一致的延长电缆；

- 7、拉住调节拉把将机器手柄调节至合适操作位置；
- 8、按下位于手柄上方的蓝色按钮同时拉住左、右拉把即可启动机器；
- 9、操作时，双手必须牢牢握住操作手柄；只要轻轻地抬起手柄，机器便会向右移动，轻轻按下手柄，机器便会向左移动；
- 10、停机时，只需松开左、右拉把即可；

机器组件

机器描述

- 全新结构设计
- 17" 铝合金壳体
- 16" 针座，15" 刷盘
- 工程塑料齿轮
- 缓冲装置，静音，易操作
- 通用卡扣座
- 安全锁定开关
- 15M 电线

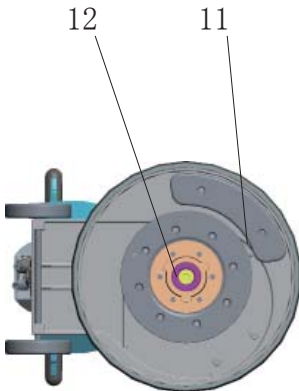

机器结构

- | | |
|-----------|---------|
| 1. 电机 | 2. 运输轮 |
| 3. 铝套座 | 4. 开关拉把 |
| 5. 安全锁定开关 | 6. 调位拉把 |
| 7. 手柄 | 8. 水箱 |
| 9. 电机罩 | 10. 壳体 |
| 11. 配重块 | 12. 卡扣座 |

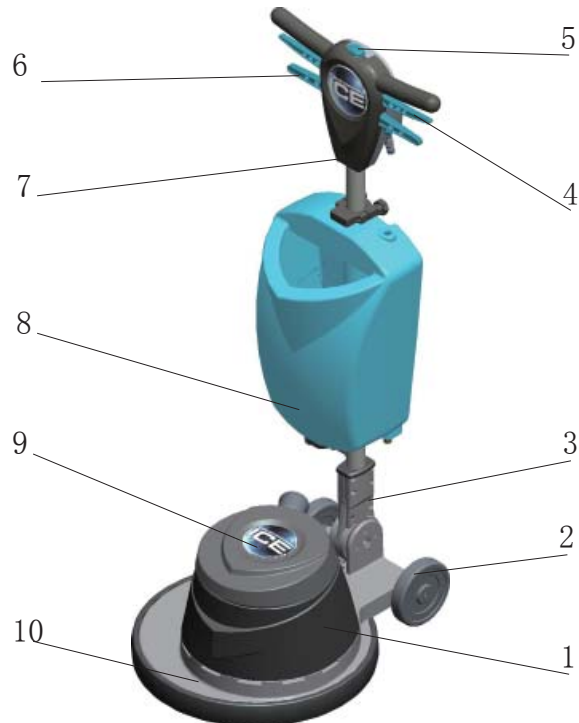

泡箱组件

- | | | |
|-----------|----------|------------|
| 1. 电机散热窗 | 2. 箱体 | 3. 发泡过滤器旋钮 |
| 4. 泡量调节旋钮 | 5. 放气按钮 | 6. 前盖 |
| 7. 注水口 | 8. 固定手柄 | 9. 过滤器 |
| 10. 电源线 | 11. 出泡接头 | |

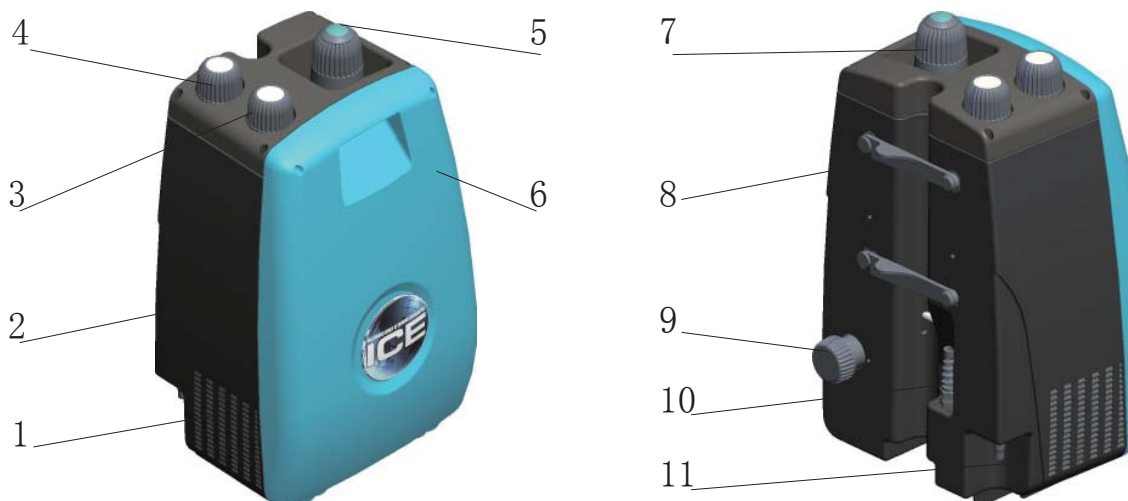

泡箱操作指引



为了达到完美的效果，请按下列要求操作。

1. 安装：将“ICE”洗地机非工作状态放置，将泡箱卡入洗地机主管上，并用手柄固定；然后用塑料管将泡箱出泡接头与洗地机放水接头连接；泡箱电源线插入手柄后盖插座。
2. 溶液配制：“ICE”专用发泡药水与清水按 1：15 比例混合，请将溶液缓缓注入水箱中。
3. 地毯清洗：安装洗地毯刷，调整洗地机到工作状态，逆时针旋转泡量调节旋钮，“1”最小，“3”最大。3-5 秒后，观察出泡量大小及干湿程度（干湿程度与泡量大小成反比）。可根据需要继续调节，直至泡量最大。释放洗地机开关拉把即可工作。顺时针旋转泡量调节旋钮到底，泡箱即停止工作。

泡箱保养

1. 定期清洗散热滤网，发泡过滤网，清水滤网。
2. 在工作中，如果发现出泡量明显减少，请检查并清洗过滤网，发泡过滤网。
3. 发泡过滤网清洗：旋下发泡过滤器旋钮，然后取下不锈钢滤网，用清水冲洗数次，装回原处。
4. 清水过滤网清洗：旋下滤网盖，取下大小滤网，用清水冲洗数次，装回原处。
5. 散热滤网更换：拆下前盖，取下即可。
6. 水箱中未使用完的溶液，要彻底放尽。避免长时间不使用，产生沉淀物，堵塞管道。

SPECIFICATIONS

Model	IF17	IFG6
Voltage	220 V	220V
Power	1.25HP	120W
Current	6.5 A	1A
Frequency	50Hz	50Hz
Speed	150rpm	-
Deck Size	17" (43 cm)	-
Length of Power cord	15 m	0.75m
Weight	43 Kg	8Kg
Solution Tank	19L	6L
Dimension LXWXH	83.8X50X195 cm	35X40X51 cm

WEAR & TEAR PARTS LIST

DIA NO	PART NUMBER	DESCRIPTION	NO REQ'D	MACHINE
1	4210116	WHEEL,5" 轮子	2	IF17
2	9021017	15"BRUSH WITH FOAM SLOT 带泡槽洗地刷	1	IF17
3	9020017	15"BRUSH 洗地刷	1	IF17
4	9010016	16"PAD 针座	1	IF17

Wiring Diagram

IF17

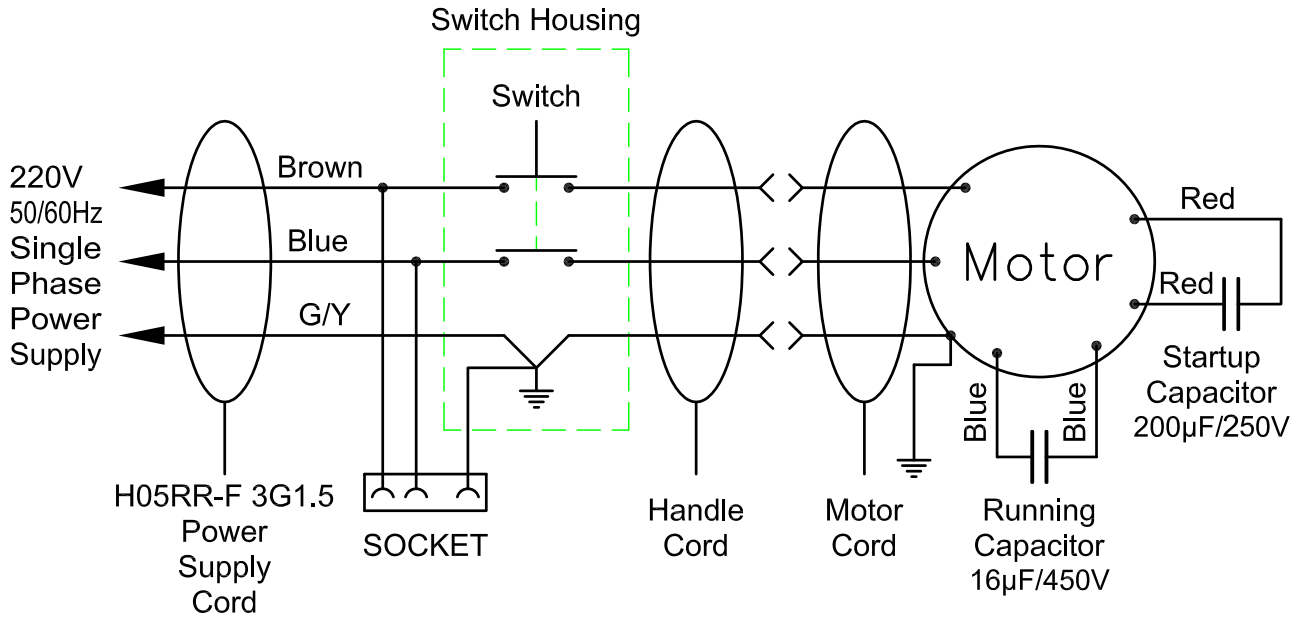

IFG6

